

# Fit it & Forget it

## Water Heater

HSE-SAS 6, 10, 15, 25 Litres



Why people prefer an A. O. Smith water heater...



### ADVANCED TECHNOLOGY

Blue Diamond® glass lined tank. Maximum protection against hard water and corrosion.



### SUPERIOR QUALITY

Get the best quality that ensures you have a water heater that works in Indian water conditions.



### EXPERT SERVICE

Guaranteed\* A. O. Smith Service within 24 hours.  
Call: 1.800.103.2468



### ENERGY SAVING

BEE 4 star rating. Saves time, saves energy, saves money.



### MADE BETTER

Made in India's most modern and advanced water heater factory.



# AOSmith®

Innovation has a name.

\* Conditions Apply

## User Guide



Congratulations!

And welcome to the A. O. Smith family.

We would like to thank you for the trust you have shown in choosing an A. O. Smith water heater. You can be sure it will live up to your expectations. Thousands of delighted users all over the world trust A. O. Smith water heaters for their families. This user guide will introduce you to your water heater. Follow the instructions carefully and look forward to enjoying long years of trouble-free service.

A. O. Smith is a company known for its innovative technologies and energy-efficient solutions. Ours are the only water heaters with the Blue Diamond® Glass lining for the inner container of the water heater. This cutting edge technology prevents sediment and scaling, fights corrosion and extends the life of your water heater. We also offer you an exciting range of colour options for the front panel of your water heater. Choose the one that matches your bathroom décor best.

Our customer-centric approach manifests itself in many other ways too. If you need any information or assistance with your water heater, just call us from any phone, anywhere in the country to our Toll Free Customer Care No. **1.800.103.2468**.

Or

Factory Address:

A. O. Smith India Water Heating Private Limited  
Plot No. 300, Phase-2, KIADB Industrial Area, Harohalli, Kanakapura Taluk,  
Ramanagara District - 562 112, Karnataka, India.

## About A. O. Smith

---

A. O. Smith India Water Heating Private Limited was established in 2006. Since then, the A. O. Smith team has conducted numerous focus group studies and spent endless research hours determining what India wanted in a water heater. Backed by 75 years of proven technological advances, A. O. Smith India has created a stylish design with features demanded by the Indian consumer.

The A. O. Smith plant with manufacturing facilities spread over 76,000 sq.ft. is located on 20 acres, just outside Bengaluru, in the KIADB Industrial Area, Harohalli. The India operations is the 16<sup>th</sup> A. O. Smith manufacturing facility worldwide. A. O. Smith's India plant has extensive engineering and technical resources and has the latest technologies incorporated. A. O. Smith is the first manufacturer to invest in and produce glass lined water heaters in India.

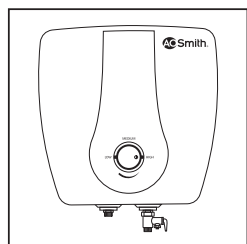
Today, A. O. Smith Corporation is one of the largest water heater manufacturers in the world and is a global leader in innovative technology and energy efficient solutions.

---

## What's in the box?

---

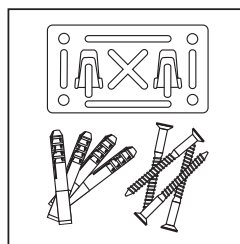
Electric  
Water Heater



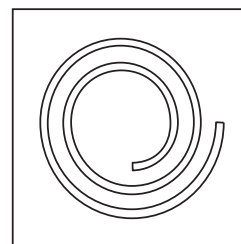
User Guide



Wall Mounting  
Accessories



Discharge Tube



---

## Contents

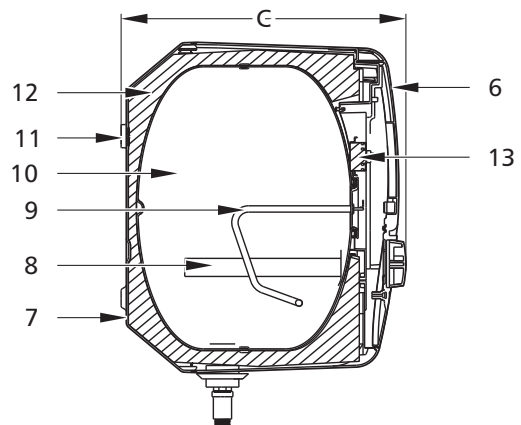
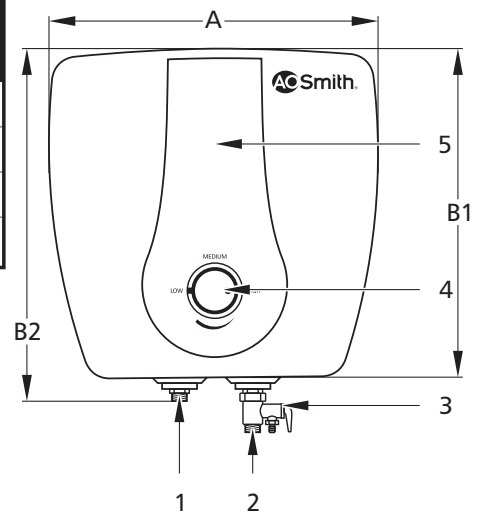
Specifications .....	1
Key Features .....	2
Installation.....	3
Directions for use.....	5
A. O. Smith ColourMatch System® .....	6
Changing the Decorative Front Panel .....	6
Troubleshooting .....	7
Circuit Diagram .....	7
Warranty .....	8
Jurisdiction .....	9
Guaranteed Service.....	9
Warranty Card .....	10
Service and Maintenance.....	11

# Specifications

Model	HSE-SAS-006	HSE-SAS-010	HSE-SAS-015	HSE-SAS-025
Volume [L]	6	10	15	25
Power [W]	2000	2000	2000	2000
Voltage/Frequency [V/Hz]	~230/50	~230/50	~230/50	~230/50
Actual Stdg. Loss [kWh/24h/45°C diff.]	0.412	0.515	0.592	0.721
Max. Stdg. Loss [kWh/24h/45°C diff.] [as per IS 2082:1993 amended in 2002]	0.792	0.990	1.138	1.386
Reheating Time for 35°C rise [in min]	6	11	18	29
Temperature range [°C]	25-75	25-75	25-75	25-75
Rated water pressure	N/cm <sup>2</sup>	80	80	80
	Water head (metres)	80	80	80
Inlet/Outlet connections [Inch]	½	½	½	½

## Dimensions

Model	HSE-SAS-006	HSE-SAS-010	HSE-SAS-015	HSE-SAS-025
A [mm]	317	373	373	444
B1 [mm]	317	373	373	444
B2 [mm]	348	405	405	483
C [mm]	258	277	348	383



### Part Descriptors

1	Outlet
2	Inlet
3	Safety Valve*
4	Temperature Control Knob
5	Decorative Front Panel
6	Front Jacket
7	Back Jacket
8	Anode
9	Heating Element
10	Tank
11	Installation Bracket
12	PU Insulation
13	Thermal Cutout

**Caution:** \*Safety valve has been factory fit with the water heater and set at 0.8 MPa (8 Bar) rated pressure.

**Warning:** Do not tamper or detach the safety valve from the water heater.

---

## Key Features

### Blue Diamond® Glass Lining

---



Blue Diamond® technology increases the life of the inner tank. The lining is stronger and more corrosion resistant than any other in the industry.

### Anode Rod

---



The tank has an anode rod which has stainless steel core that is designed to protect the tank from corrosive elements. The anode rod uses a special cathodic action to fight these elements and thus prolong the life of the water heater.

### Temperature Control Knob

---



The temperature control knob allows you to set the temperature precisely between 25°C to 75°C .

### Safety Valve

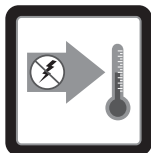
---



The safety valve is designed to automatically relieve and discharge water in case the pressure overshoots the preset limits.

### Thermal Cutout

---



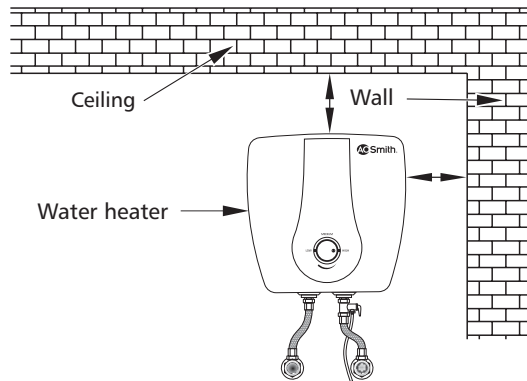
If the water temperature exceeds the highest preset level, the breaker rapidly cuts off the live line and the neutral line simultaneously to assure safety.

**Note:** A. O. Smith reserves the right to amend or modify the specifications and features at any time, as and when required without any prior notification.

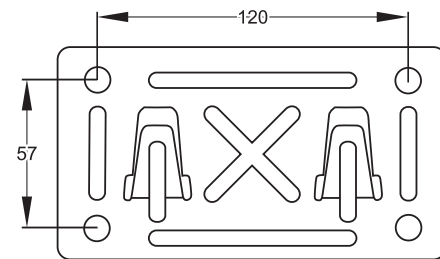
# Installation

## Mounting

**Fig. 1 Position for installation**

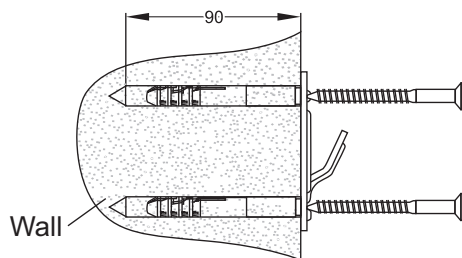


**Fig. 2 Wall mounting bracket**

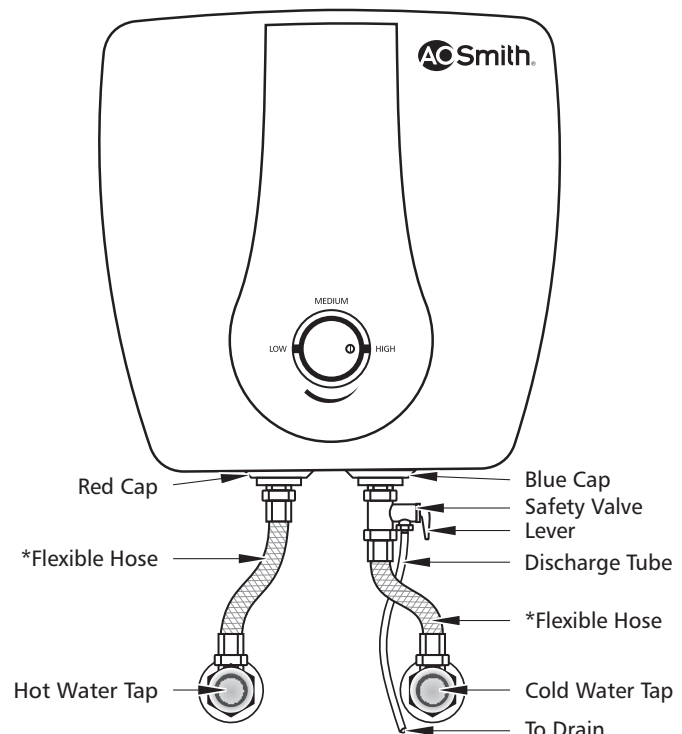


1. Make sure that the wall can withstand at least twice the weight of the water heater when completely filled with water.
2. Before locating the position for installation of the water heater, make sure that there is sufficient clearance between the ceiling and the side wall. (Fig. 1)
3. Use a drill bit with diameter of 10mm to drill 4 holes at least 90mm deep in the wall (Fig. 3). The four holes should be aligned horizontally and vertically. The horizontal distance between the 2 holes should be 120mm and the vertical distance should be 57mm. (Fig. 2)
4. Insert the expansion anchors into the holes. Place the wall mounting bracket over the expansion anchors and tighten the screws on the bracket. (Fig. 3)
5. Place the water heater on wall mounting bracket (Fig. 4) using hanger hooks. Tug downwards on the heater to ensure that the water heater is fixed steadily.

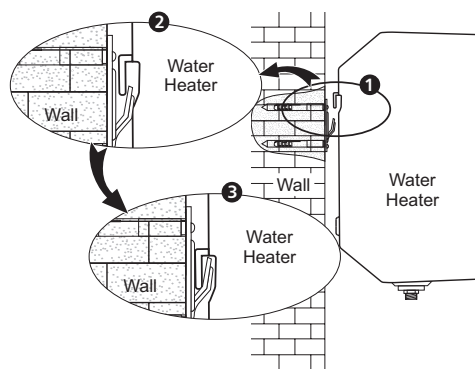
**Fig. 3 Installation of wall mounting bracket**



**Fig. 5 Installation diagram**



**Fig. 4 Inserting the water heater into mounting bracket**



\*Flexible Hoses to be procured by the customer, not part of standard product.

---

## Plumbing

---

1. Make necessary plumbing with reference to the installation diagram. (Fig. 5)
2. A. O. Smith recommends nylon/SS braided hoses having a minimum pressure rating of 8 Bar and hoses should be compatible for hot water applications.
3. Connect the cold water pipe to the inlet [Blue Cap].
4. Connect the hot water pipe to the outlet [Red Cap].
5. Attach the discharge tube to safety valve as shown in installation diagram. (Fig. 5 & 6)

### Attention:

- Make sure a suitable sealing tape is used for all connections to prevent leakage.
- Discharge tube should be installed downwards without any loops, folds or knots. Ensure that the free end of the discharge tube is placed over a suitable drain and away from the users.
- Discharge tube is provided to release the discharge from the water heater(through the safety valve) in case excessive pressure is developed. The contents of the discharge from the Safety valve may be hot and may cause burns to the users and damage nearby objects if not properly routed to a drain.
- It is recommended to operate the discharge lever in the safety valve on a regular basis to ensure that there are no blockages and also to remove any lime deposits that would have been formed inside the water heater.
- Ensure that the water heater is in power OFF condition when the Discharge lever is being operated. Ensure that the water is filled completely in the water heater before switching it ON.

## Water Filling

---

1. Open a hot water faucet nearby to permit the air to escape.
2. Open the cold water inlet valve fully, filling the heater and the piping.
3. Close the hot water faucet when water flows.
4. Check all the connections to see if there is any leakage. In case of a leakage, drain the heater completely, repair the leaking joint and then refill the heater.

## Electrical Connections

---

The power cord and plug are connected with this water heater. Find a separate socket for power plug and make sure the socket is in firm contact with the plug. Ensure that reliable earthing has been done.

### Caution:

- Connect the water heater using independent sockets, do not use adapters. Use multimeter to check whether the live line and neutral line are not reverse, to ensure complete safety.
- Before installing the water heater, confirm that the power of water heater matches electric meter capacity and supply wire.
- The water heater should be earthed reliably. It is prohibited to connect the earth wire to neutral wire or tap water pipe.

---

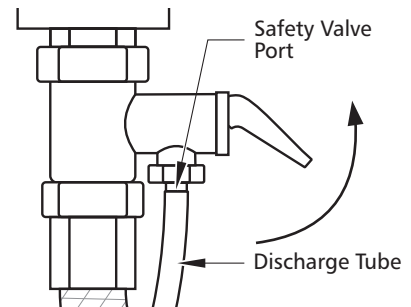
## Draining

---

For draining water from the water heater, following steps needs to be followed:

1. Switch off the electric supply to the water heater.
2. Open the hot water taps until the water is not hot any more.
3. Close cold water supply.
4. Drain the water by moving the lever of safety valve in the direction of the arrow as indicated in the diagram. (Fig. 6)

**Fig. 6 Safety valve**



### Caution:

- Before using the water heater, make sure that it should be completely filled with water.
- Please turn off the power supply to the water heater prior to draining the water heater.

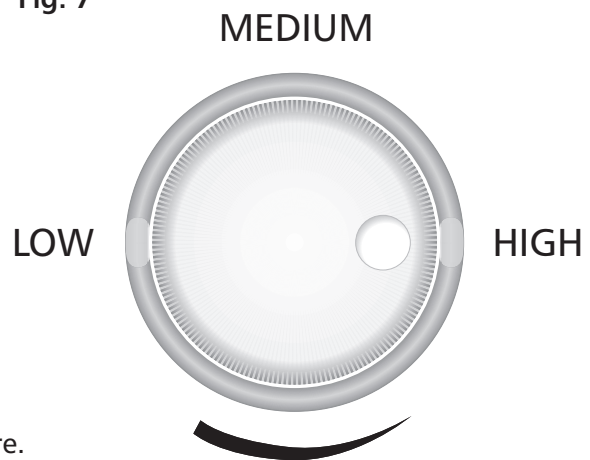
**Warning:** This water heater should not be operated with insufficient amount of water. Failure to do so may result in damage to the water heater & injuries to the users. This will also make the warranty null & void.

---

## Directions for use

**Caution:** Before using the water heater, make sure the inner tank is completely filled with water and the power plug has been connected properly.

1. Switch on the water heater's power supply. **Fig. 7**  
The green indicator light glows.
2. Turn the thermostat knob clockwise for the device to commence heating and change the set temperature. A **red** light will glow. [The set temperature increases if the thermostat knob is turned clockwise.] Temperature can be set in the range of 25°C to 75°C. Recommended to keep thermostat knob notch position always in **medium or above** level.
3. The red light's switching off indicates the heater has been heated to the set temperature.



### Caution:

- Once the mounting, plumbing, discharge tube, power connection and water filling is completed, then only the power supply should be given.
- During repair or periodic maintenance, if necessary, the power cord or Internal electrical wiring should be replaced by A. O. Smith Authorised service personnel only.
- It is not permitted for the power supply plug and cord to be replaced or altered by unauthorised people or by the users themselves. This will make the warranty null and void and may cause the water heater operation hazardous.



## A. O. Smith ColourMatch System®



**Attention:** The product of your choice comes with either white or ivory as a front panel of the same colour. You have the option of changing this panel to match your bathroom décor at a **nominal cost**.

A. O. Smith ColourMatch System® allows you to match your water heater to the colour of your bathroom.

Please visit [www.aosmithindia.com](http://www.aosmithindia.com) and choose your Decorative Front Panel colour options. Call A. O. Smith Customer Care Centre [1.800.103.2468] to order the Decorative Front Panel.

## Changing the Decorative Front Panel

Please follow the instructions as shown in Fig. 8

### Fig. 8 Removing decorative front panel

Pull out the Knob



Unscrew



Remove the Decorative Front Panel to change



### Warning:

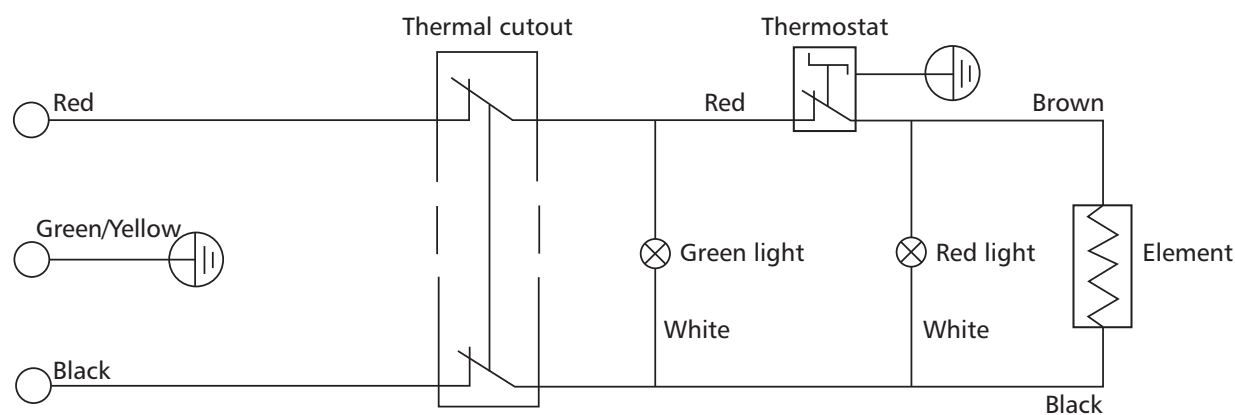
- Please ensure to switch off the power supply while changing the Decorative Front Panel and pull out the power plug from the socket.
- An insulation layer is provided below the front panel which should not be replaced.
- While changing the front panel ensure that, none of the internal components are damaged or removed.

# Troubleshooting

Problem	Possible Cause(s)	Solution
<ul style="list-style-type: none"> <li>Green and Red light off</li> <li>No hot water</li> </ul>	No power to heater	Turn on electrical switch. Check for blown fuses or tripped breaker
	Thermal cutout switch open	Call Customer Care Centre
	Control circuit or internal wiring error	Call Customer Care Centre
<ul style="list-style-type: none"> <li>Green light on Red light off</li> <li>No hot water</li> </ul>	Non-functioning thermostat	Call Customer Care Centre
	Control circuit or internal wiring error	
<ul style="list-style-type: none"> <li>Water temperature is too high</li> </ul>	Thermostat set is too high	Call Customer Care Centre
	Thermal cutout trips	Call Customer Care Centre
<ul style="list-style-type: none"> <li>Water heats slowly</li> </ul>	Non-functioning element	Call Customer Care Centre
<ul style="list-style-type: none"> <li>Thermostat does not shut off</li> </ul>	Non-functioning thermostat	Call Customer Care Centre
	Improper calibration	Call Customer Care Centre
<ul style="list-style-type: none"> <li>Piping connection leaks</li> </ul>	Connection not sealed	Call plumber
<ul style="list-style-type: none"> <li>Leaky cover</li> </ul>	Tank or parts leak	Shut off power immediately and Call Customer Care Centre

**Note:** Call Customer Care Centre on 1.800.103.2468

## Circuit Diagram



---

# Warranty

## Product warranty

---

Your A. O. Smith water heater is warranted against defects arising from faulty design, workmanship and materials for a period of 24 months from the date of the invoice, subject to the following conditions:

1. The customer will notify the Company promptly about defects noticed and give the Company or its Authorised service provider adequate opportunity to inspect, test and remedy them, for which the customer will deposit the goods, if necessary, with the Company's Office/Authorised service provider along with the original invoice.
2. Special warranty from the date of purchase is subject to the following conditions:
  - Tank - 7 Years
  - Incoloy Heating Element - 2 + 1 Years\*
  - Rest of the parts - 2 Years
3. Inspection and Test Report of the Company's Office/Authorised service provider will be treated as final and binding under the warranty for determining the defects, repairs/alterations required or carried out, or certifying working of the goods thereafter.
4. The Company or its Authorised service provider will be entitled to retain any defective part replaced under the warranty.
5. The Company's liability under the warranty will be limited only to defects which occur under conditions of proper installation, normal operation and under proper use. It excludes defects occurring because of abuse, faulty care or maintenance and repairs/alterations to product or the parts by unauthorised person.
6. Components subject to wear, such as anode, are not covered under this warranty.
7. The customer will have no claim under this warranty in respect of any personal injury, damage or property or consequential damages, or for utilisation of the goods not in accordance with the user guide.



\* Register your product with the A. O. Smith Customer Care Centre [1.800.103.2468] within two months of purchase and you will get an extended warranty on the element [from 2 years to 3 years]. You can also get an additional changeable Decorative Front Panel in a colour of your choice, with a nominal cost.

---

## General Terms of Warranty

---

1. The "goods" shall mean the goods described in the purchase agreement.
2. "The customer" shall mean the original purchaser under the purchase agreement.
3. "The Company" shall mean A. O. Smith India Water Heating Pvt. Ltd.
4. The "Purchase Agreement" shall mean the General Terms and Conditions of Sale agreed upon by the customer and the Company as printed on the Invoice.
5. "Invoice" shall mean the Invoice issued for the Unit by the Company or Authorised Dealer to the customer describing the goods and indicating, inter alia, the total purchase price thereof, the name of the customer and the place where the goods are to be installed.
6. "User Guide" shall mean the instructions for installation leaflet published by the Company and delivered to the customer.

**Note:** Follow any one for registration of the Extended Warranty

- Call our dedicated Customer Care Centre **1.800.103.2468**.
- Fill up the details in our website link (<http://www.aosmithindia.com/warranty-form.aspx>) to register.
- Fill up the details in the Warranty Card and mail the same to A. O. Smith India Water Heating Pvt. Ltd., factory address.

## Post Warranty

---

1. The customer may be offered a yearly Service Contract at the prevailing Company rates and terms.
2. In case the customer does not wish to enter the Service Contract, he has the option of calling our Authorised service provider and having his A. O. Smith Water Heater unit serviced on actual basis i.e. by paying the Labour Cost and Spares needed to attend to that Service or Complaint Call at the prevailing Company rates. Such service will be rendered by the Company in towns or places where the Company has its Authorised service providers.
3. In case of product repair after warranty by Authorised service provider, all expenses of transporting the goods to and from the Authorised service provider shall be borne by the customer directly.
4. If, during such service, it is necessary for the Company or Authorised service provider to replace or repair defective components or parts, the customer shall be required to pay for the same as per the Company's prevailing price list.

---

## Jurisdiction

The courts of competent jurisdiction at Bengaluru, Karnataka shall have exclusive jurisdiction over all matters arising out of any disputes in relation to the product.

---

## Guaranteed Service

1. Different models has different service delivery levels.
2. Service level mentioned for particular models are applicable for Metros & A Class Cities e.g. Delhi & NCR, Bangalore, Hyderabad, Mumbai, Kolkata, Pune, Goa, Cochin, Chennai, Chandigarh & Ahmedabad.
3. Service level deliverables are valid up to city municipal limit only.
4. Service level may differ in case of public holidays & unavoidable conditions due to natural climate, any political & regional regulations.

---

## Warranty Card

### Warranty Card (Customer Copy)

(To be retained by the Customer) Unit Serial Number: \_\_\_\_\_

Invoice Number: \_\_\_\_\_ Dated: \_\_\_\_\_

Customer's Name and Address: \_\_\_\_\_

\_\_\_\_\_

\_\_\_\_\_

Model: \_\_\_\_\_ Capacity: \_\_\_\_\_

Dealer's Stamp and Signature

---

## Warranty Card

### Warranty Card (Company Copy)

(To be sent back to the Company) Unit Serial Number: \_\_\_\_\_

Invoice Number: \_\_\_\_\_ Dated: \_\_\_\_\_

Customer's Name and Address: \_\_\_\_\_

\_\_\_\_\_

\_\_\_\_\_

Model: \_\_\_\_\_ Capacity: \_\_\_\_\_

Dealer's Stamp and Signature

---

## Service and Maintenance

### For Service needs:

Please contact our A. O. Smith  
Toll Free Number : 1.800.103.2468  
SMS us : +91770.292.8887  
Email us : [aosmithcs@hotmail.com](mailto:aosmithcs@hotmail.com)

For grievances please contact : [wecare@hotmail.com](mailto:wecare@hotmail.com)

---

## Registered Office

### A. O. Smith India Water Heating Private Limited

Plot No. 300, Phase-2, KIADB Industrial Area, Harohalli, Kanakapura Taluk,  
Ramanagara District - 562 112, Karnataka, India.

■ Toll Free No.: 1.800.103.2468 ■ Website: [www.aosmithindia.com](http://www.aosmithindia.com)

## Regional Office

### Delhi:

105 & 106, Plot No. 19, Sagar Plaza, Laxmi Nagar District Centre,  
Vikas Marg, Laxmi Nagar, New Delhi - 110 092.

### Kolkata:

224 A, Office No. 811, 8th Floor, Krishna Building, AJC Bose Road,  
Kolkata - 700 017.

### Mumbai:

Sanjar Enclave, No. 509, CTS No. 428, S.V. Road,  
Opp. Milap Cinema, Kandivali (West), Mumbai - 400 067.

### Pune:

401 & 402, Citi Mall, Ganeshkhind Road, Near Pune University,  
Pune - 411 007.





**Manufactured by A. O. Smith India Water Heating Private Limited**

Plot No. 300, Phase-2, KIADB Industrial Area, Harohalli, Kanakapura Taluk, Ramanagara District - 562 112, Karnataka, India.

Toll Free: 1.800.103.2468 ■ Website: [www.aosmithindia.com](http://www.aosmithindia.com)

Part No.: 322858-000\_R1 Dt: 19-04-2013